

Grubość profilu

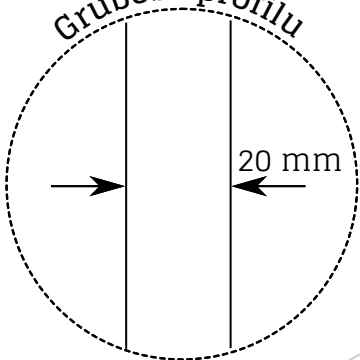

elementy bramy

- 1 Daszek 80x80 mm (2 szt.)
- 2 Klamka + wkładka + zamek ..(1 kpl.)
- 3 Słup 80x80 mm (2 szt.)
- 4 Zawias M16 (90° lub 180°).... (4 szt.)
- 5 Rygiel + ogranicznik.....(1 szt.)
- 6 Profil ramy 40x40 mm
- 7 Profil 20x20 mm
- 8 Profil 20x20 mm

warstwy ochronne

- O cynk
- Pasywacja
- Kolor RAL

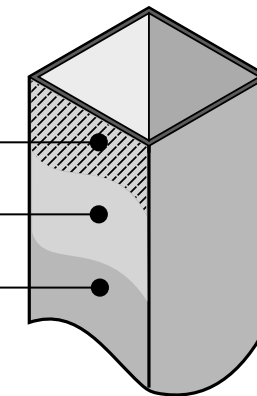

DUPLEX



DUPLEX - ocynk ogniowy plus malowanie proszkowe (wg normy PN-EN 10244-2 i PN-EN 10245-4)

wymiary bramy (mm)

- A szerokość zawiasu 55-75
- B szerokość słupa 80
- L₁ światło wjazdu
- L₂ szerokość montażowa bramy = $L + 2 * B + 2 * C$
- H₁ wysokość słupa = $H + 600$
- L szerokość bramy (wymiar zamówieniowy)
- H wysokość bramy (wymiar zamówieniowy)

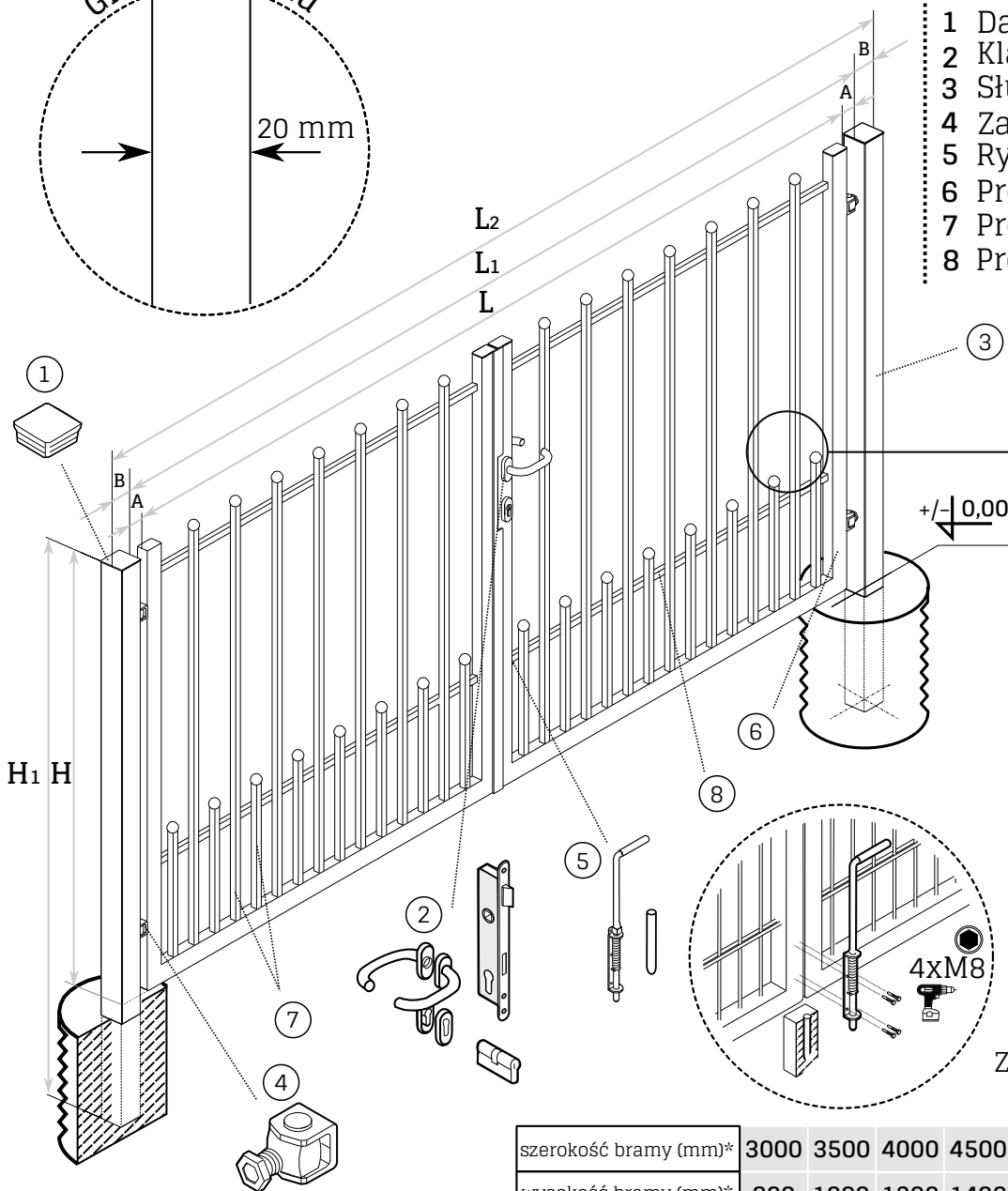

Zakres regulacji rygla:
10 - 50 mm

szerokość bramy (mm)*	3000	3500	4000	4500	5000	5500	6000
wysokość bramy (mm)*	800	1000	1200	1400	1600	1800	2000

*inne wymiary dostępne na zamówienie

typ klamki i rygla

standard

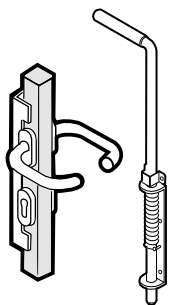

Locinox (opcja)

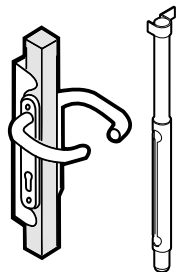

centrala zasilająca

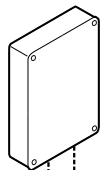

napęd do bramy (opcja)

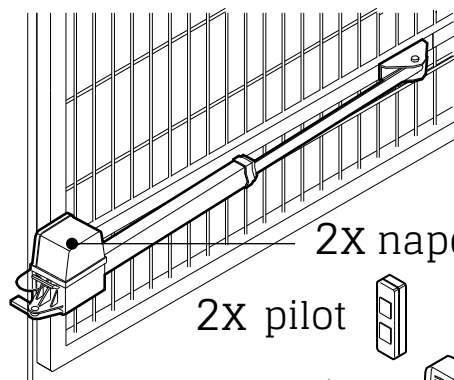

2X napęd

2X pilot

2X fotokomórka

warianty mocowania

w fundamencie

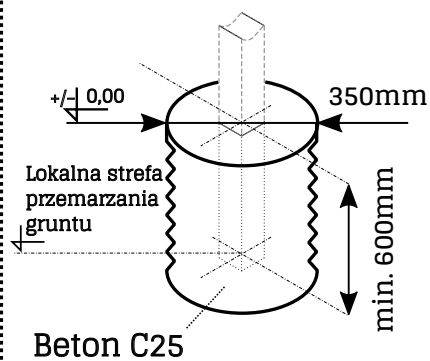

na stopie stalowej (opcja)

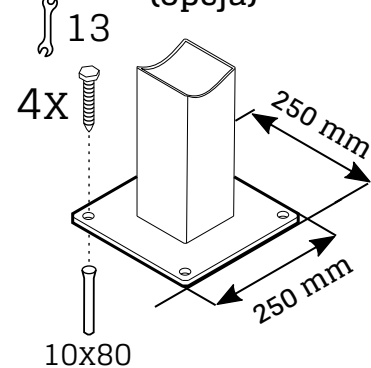

zawiasy

M16 - 90°

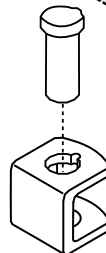
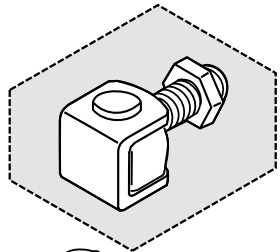

0-90°

skrzydło → ← słup

55-75mm

M16 - 180° (opcja)

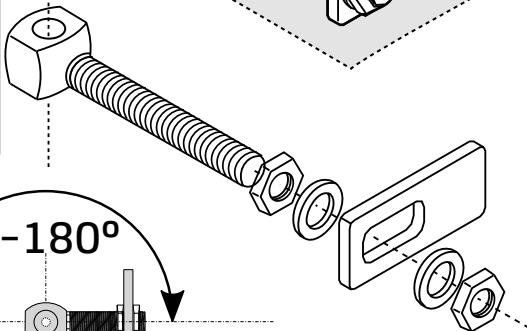
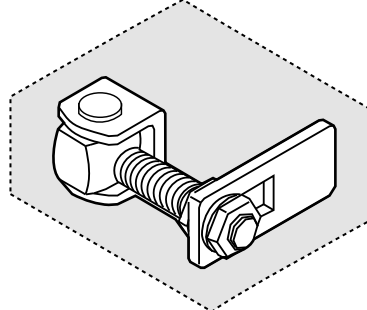

0-180°

→ słup ← skrzydło

20-110mm

elementy klamki standard



+ PH2

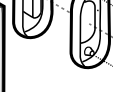
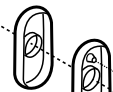

PH2

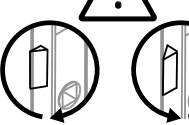
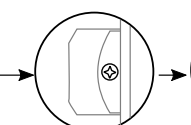

3X

